

Series 1780

Thrust Stand and Dynamometer

Optimize the performance of your large-scale UAV with the Series 1780. The dynamometer measures key performance data such as thrust, torque, electrical power and RPM in order to help you increase flight time and efficiency.

Features and Advantages

- For propellers up to 47".
- Motor and propeller characterization and performance comparison.
- For research, development and quality assurance.
- Optimized profile to reduce air drag.
- Software included for control and data logging with a USB interface.
- Real-time plotting and CSV file output.

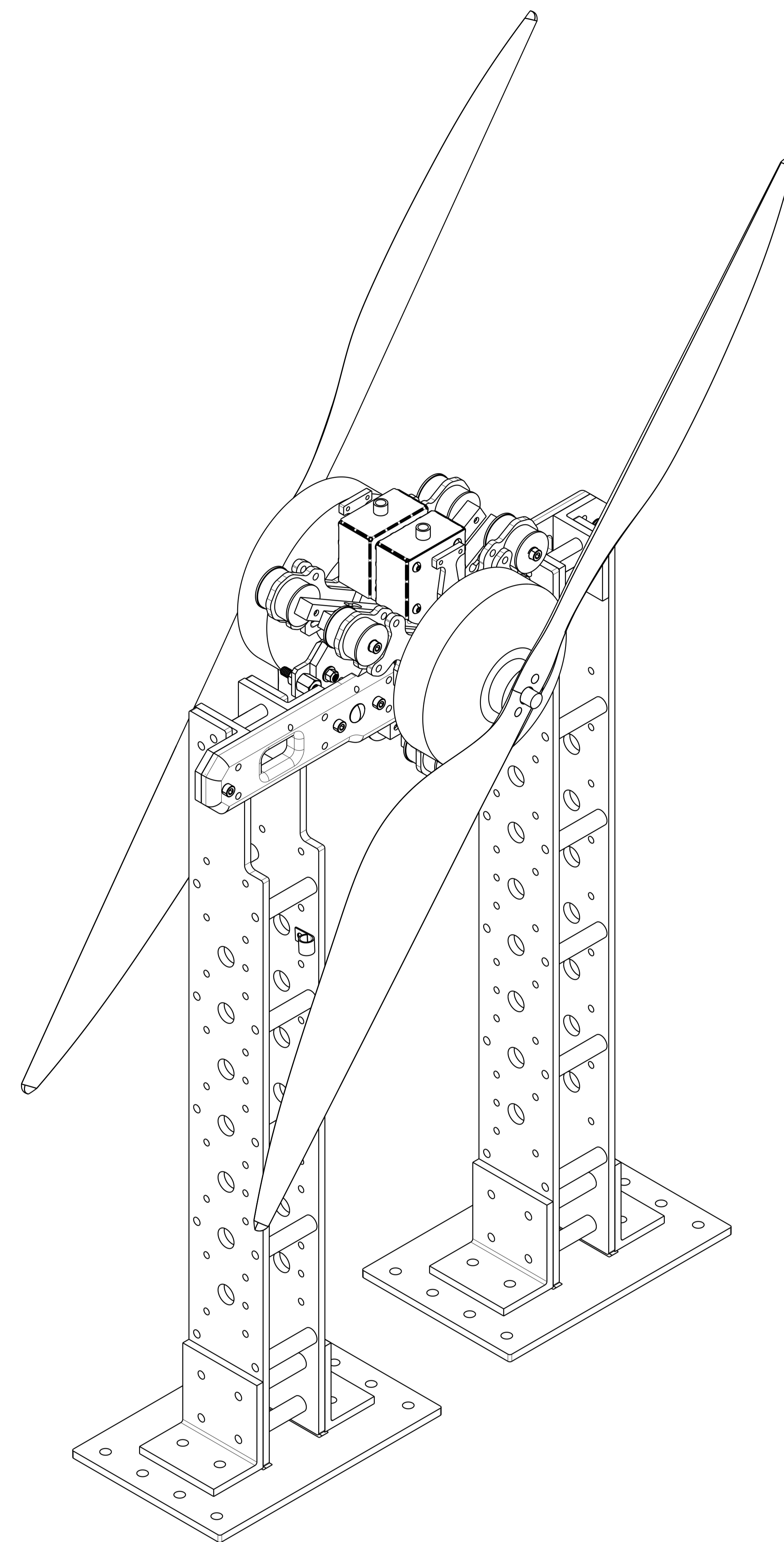

Available motor setups

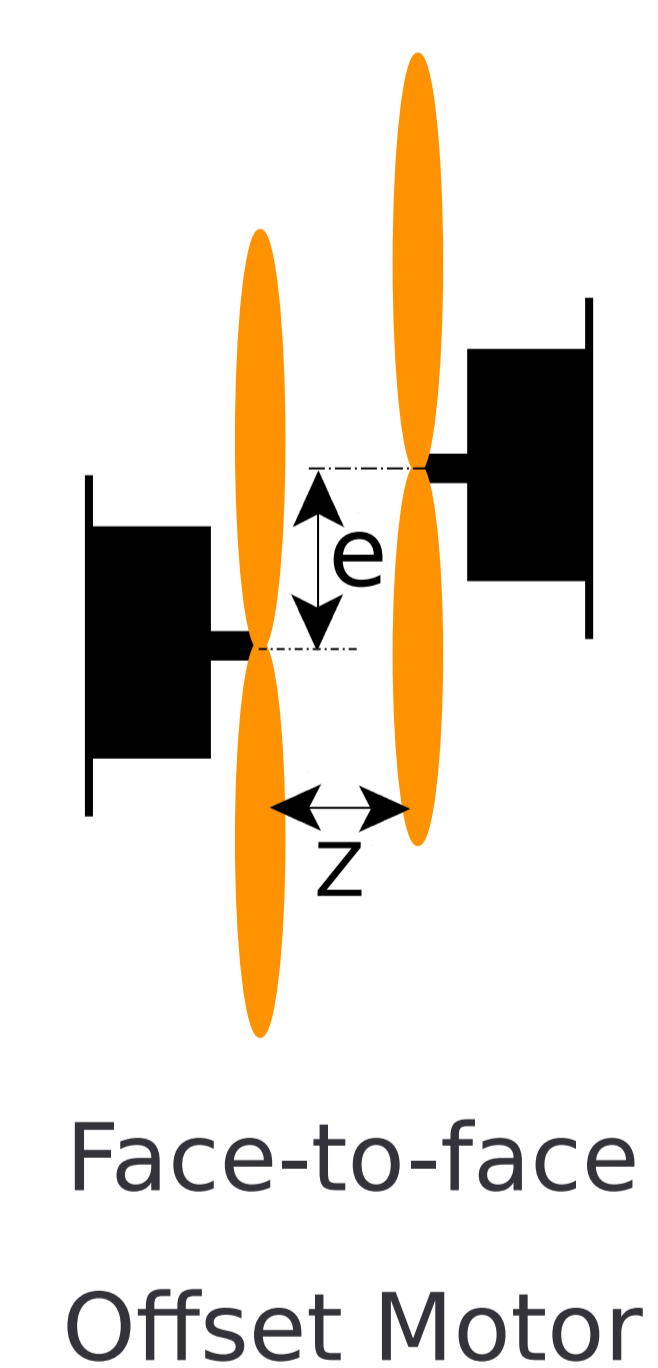
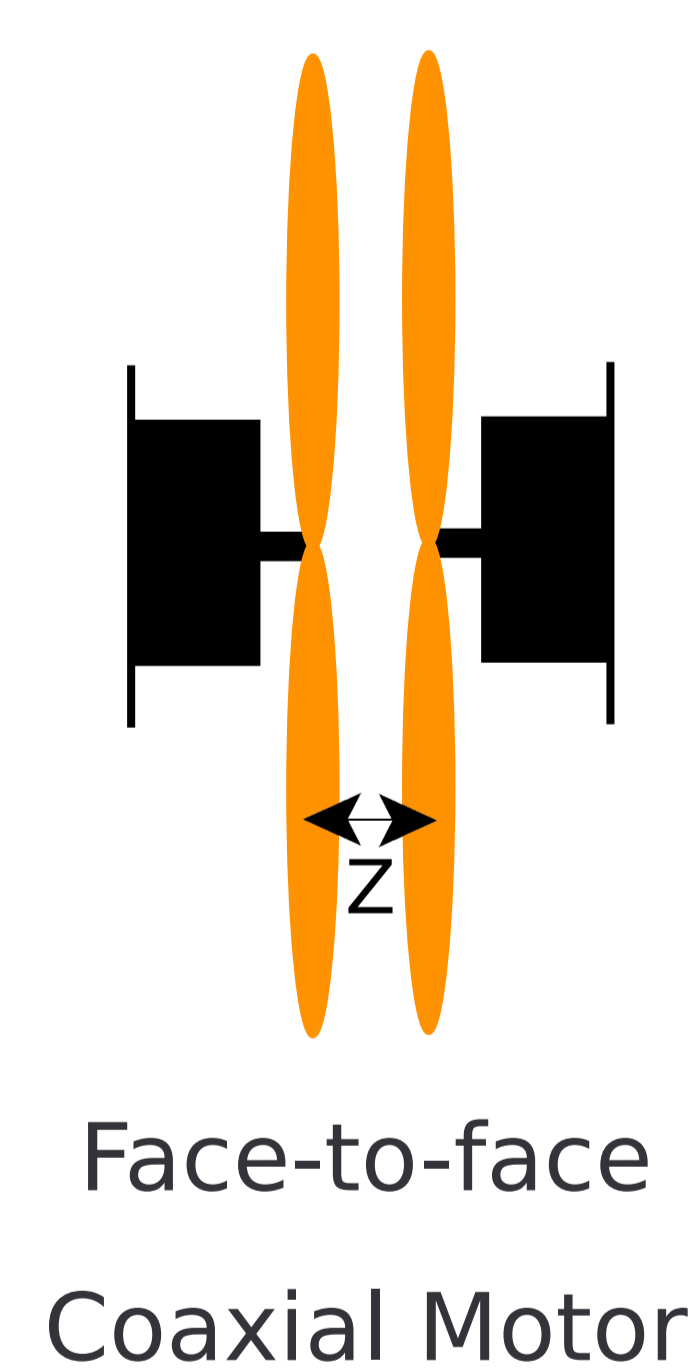
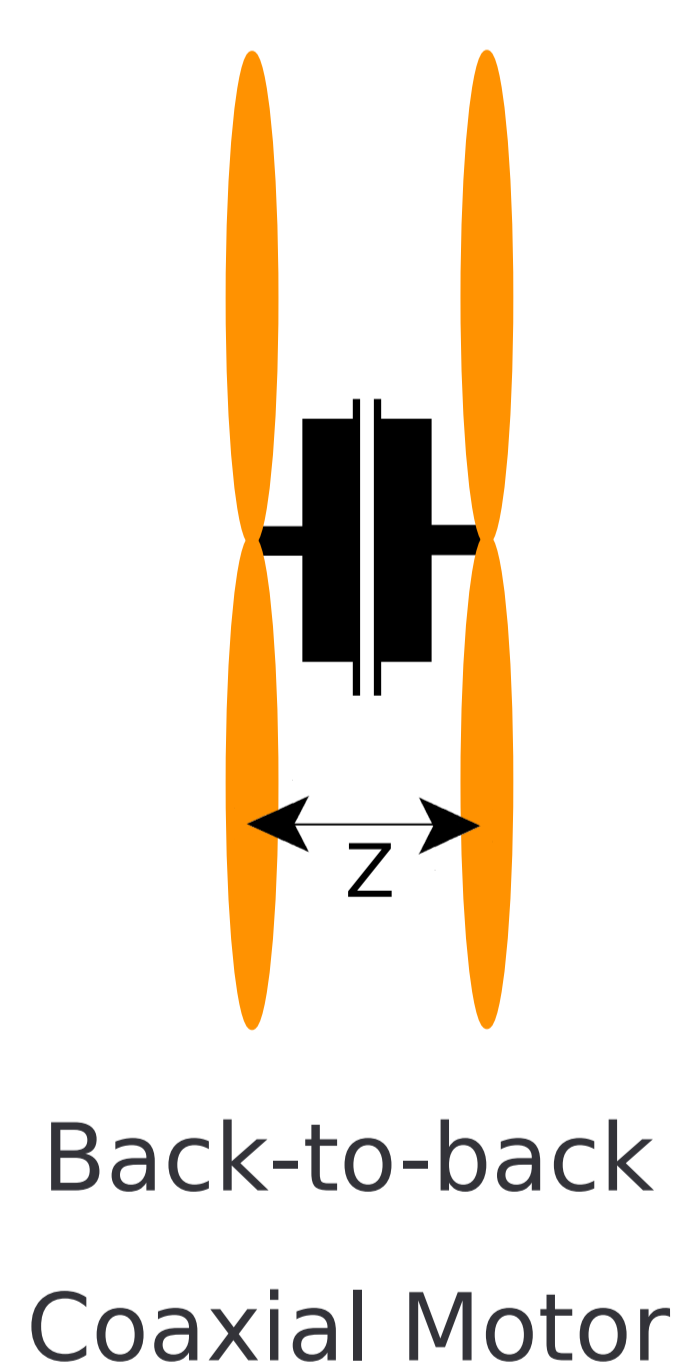
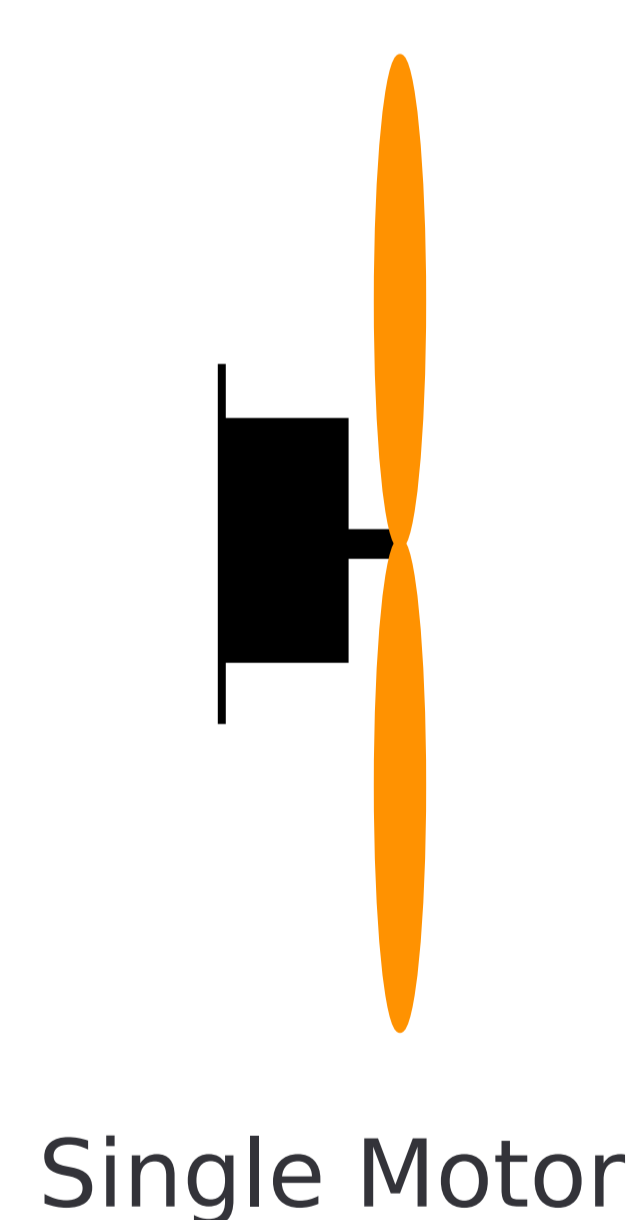

Sample Dual-Motor Data

