

e.series

Manual

e.bloxx A4TC



© Copyright 2004 by GANTNER INSTRUMENTS Test & Measurement GMBH, Schruns (Austria).

Copyrights: Operating instructions, manuals and software are protected by copyright ©. All rights are reserved. Copying, duplication, translation, installation in any electronic medium or machine-readable form in whole or in part is prohibited. The sole exception is represented by creation of a back-up copy of software for own use as a safeguard, so far as this is technically possible and recommended by us. Any infringement will render the party committing such infringement liable to compensation payment.

Liability: Any claims against the manufacturer based on the hardware or software products described in this manual shall depend exclusively on the conditions of the guarantee. Any further-reaching claims are excluded, and in particular the manufacturer accepts no liability for the completeness or accuracy of the contents of this manual. The right is reserved to make alterations, and alterations may be made at any time without prior notice being given.

Trade marks: Attention is drawn at this point to markings and registered trade marks used in this manual, in particular to those of Microsoft Corporation, International Business Machines Corporation and Intel Corporation.



Important: Before commencing installation, commissioning, putting into service and before any maintenance work is carried out, it is essential that the relevant warning and safety instructions in this manual are read!

**General warning and safety instructions:**

Dear customer,

We congratulate you on having selected a product of Gantner Instruments Test & Measurement GMBH. So that our product functions in your installation with safety and to your complete satisfaction, we take this opportunity to familiarize you with the following ground rules:

1. Installation, commissioning, operation and maintenance of the product purchased must be carried out in accordance with instructions, i.e. in accordance with the technical conditions of operation, as described in the corresponding product documentation.
2. Before installation, commissioning, operation or maintenance it is therefore essential that you read the corresponding chapter of this manual and observe its instructions.
3. If there are still some points on which you are not entirely clear, please do not take a chance, but ask the customer adviser responsible for you, or ring the Gantner Instruments Test & Measurement GMBH hot line.
4. Where not otherwise specifically laid down, appropriate installation, commissioning, operation and maintenance of the appliance is the customer's responsibility.
5. Directly on receipt of the goods, inspect both the packaging and the appliance itself for any signs of damage. Also check that the delivery is complete (-> accessories, documentation, auxiliary devices, etc.).
6. If the packaging has been damaged in transport or should you suspect that it has been damaged or that it may have a fault, the appliance must not be put into service. In this case, contact your customer advisor. He will make every effort to resolve the problem as quickly as possible.
7. Installation, commissioning and servicing of our appliances must only be carried out by suitably trained personnel. In particular, correspondingly qualified specialists may only make electrical connections. Here, the appropriate installation provisions in accordance with the relative national Electrical Engineers construction regulations (e.g. ÖVE, [Austrian] VDE, [German]...) must be observed.
8. Where not otherwise stated, installation and maintenance work on our appliances is exclusively to be carried out when disconnected from the power supply. This applies in particular to appliances that are normally supplied by low-tension current.
9. It is prohibited to make alterations to the appliances or to remove protective shields and covers.
10. Do not attempt yourself to repair an appliance after a defect, failure or damage, or to put it back into operation again. In such cases, it is essential you contact either your customer adviser or the Gantner Instruments Test & Measurement GMBH hot line. We will make every effort to resolve the problem as quickly as possible.
11. Gantner Instruments Test & Measurement GMBH accepts no responsibility for any injuries or damage caused as a result of improper use.

12. Although every care is taken and we are continuously aiming for improvement, we cannot exclude completely the possibility of errors appearing in our documentation. Gantner Instruments Test & Measurement GMBH therefore accepts no responsibility for the completeness or the accuracy of this manual. The right is reserved to make alterations, and we may carry out alterations at any time without giving prior notice.

13. Should you discover any fault with the product or in its accompanying documentation, or have any suggestions for improvement, you may confidently approach either your customer adviser or Gantner Instruments Test & Measurement GMBH directly.

14. However, even if you just want to tell us that everything has functioned perfectly, we still look forward to hearing from you.

We wish you a successful application of our appliances. We will be pleased to welcome you as a customer again soon.

Contact address / manufacturer:

Gantner Instruments Test & Measurement GmbH

Montafonerstrasse 8

A - 6780 Schruns/Austria

Tel.: +43 5556 73784 - 410

Fax: +43 5556 73784 - 419

E-Mail: office@gantner-instruments.com

Web: www.gantner-instruments.com

Gantner Instruments Test & Measurement GmbH

Industriestraße 12

D-64297 Darmstadt

Tel.: +49 6151 95136 - 0

Fax: +49 6151 95136 - 26

E-Mail: testing@gantner-instruments.com

Web: www.gantner-instruments.com

TABLE OF CONTENTS

1.	ABOUT THIS MANUAL	6
2.	MODULE DESCRIPTION	7
2.1.	System Overview	7
2.2.	Types of Modules	8
2.3.	Module Parts	9
2.4.	Functional Overview	10
2.5.	Front-LED	10
2.6.	DC-Isolation.....	10
2.7.	Functional Diagram	11
3.	MOUNTING E.BLOXX AND CONNECTING WIRES	12
3.1.	Environmental Conditions	12
3.2.	Connection Technique	12
3.3.	Power Supply	12
3.4.	Bus Connection	13
3.5.	Shielding.....	18
3.6.	Rapid Bus Link Plug.....	18
4.	MEASUREMENTS	20
4.1.	General.....	20
4.2.	Analog Input - Measurement of Temperature with Thermocouples.....	20
4.3.	Analog Input - Measurement of Voltage.....	22
5.	CONFIGURATION	23
5.1.	General Information about Configuration Software ICP 100.....	23
5.2.	Setting Address and Baud Rate of an e.bloxx	23
5.3.	e.bloxx Settings	24
5.4.	Definition of Channels	25
6.	SPECIFICATIONS	26
6.1.	Analog Inputs	26
6.2.	Analog/Digital Conversion.....	26
6.3.	Communication Interface	26
6.4.	Power Supply	27
6.5.	Mechanical	27
6.6.	Connection	27
6.7.	Environmental Conditions	27
7.	DECLARATION OF CONFORMITY	28

1. ABOUT THIS MANUAL

This manual describes the installation and setup of the e.bloxx A4-1TC and A4-4TC modules. Those modules only differ in their amount of analog inputs. So in this manual the e.bloxx A4-1TC is described and shown in the pictures and at every point where there are differences between the e.bloxx A4-1TC and the A4-4TC there will be a special note.

The following information can be found in this manual:

- Description of the e.bloxx system with detailed information on the hardware and module features.
- Installation description of the modules and how they are connected to the power supply and bus lines.
- Description of the different types of measurement (voltage measurement and thermocouples).
- A short introduction on how the e.bloxx modules are configured with the CONFIGURATION SOFTWARE ICP 100.
This software has an integrated help including a detailed description of the configuration process.
- Possible errors and its solutions.
- Technical specifications of the modules.

2. MODULE DESCRIPTION

2.1. System Overview

The e.bloxx modules have been developed for the industrial and experimental testing technology, especially for the multi-channel measurement of electrical signals of thermal or mechanical data at test beds and test sites.

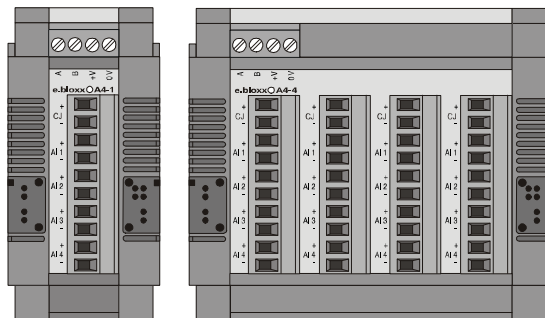

Picture 2.1 - e.bloxx A4-1TC and A4-4TC

The e.bloxx A4-1TC and A4-4TC, which are described in this manual, are 4- or 16 channel modules for measurement of voltages and thermocouples. With each 4 analog input channel 4 additional channels are available for calculations, alarms and setpoints. They are part of a whole product line of different e.bloxx and differing by their number of inputs (analog or digital) and outputs.

Standardized interfaces guarantee the integration of up to 127 modules into a single network.

With the e.gate module very high data rates via Profibus-DP and Ethernet can be realized. The customer-specific signal processing supplements the standard conditioning of the single e.bloxx modules.

2.2. Types of Modules

There are several types of e.bloxx that differ in their number and type of analog and digital inputs and outputs.

	A1-1	A1-4	A1-8	A3-1	A3-4	A4-1	A4-4	A5-1	A5-1 CR	A6-1	A6-3	A6-2	A9-1	D1-1	D1-4	D2-1
Voltage Supply	10 - 30 VDC															
Power Consumption [W]	1,5	6	12	1,5	6	1,5	6	1,5	1,5	2	6	5	2,3	1,5	6	2
Variable / Channels	8	32	64	8	32	8	32	8	8	8	24	16	8	8	32	8
Analog Inputs	1	4	8	4	16	4	16	2/3/6	2	1	3	1	-	-	-	-
Analog Outputs	-	-	-	-	-	-	-	-	-	1	3	2	4	-	-	-
Relay Outputs	1	4	8	-	-	-	-	-	-	-	-	-	-	-	-	4
Digital Inputs	1	4	8	1	4	-	-	1	1	1	3	6	1	8	32	-
Digital Outputs	-	-	-	1	4	-	-	1	1	1	3	4	1	8	32	-
Fieldbus Interface	RS 485															
Protocols	ASCII - Modbus-RTU - Profibus-DP - LocalBus															
Quantity to measure Sensor Principle																
Voltage	x	x	x	x	x	x	x	-	-	-	-	-	-	-	-	-
Current	x	x	x	-	-	-	-	-	-	-	-	-	-	-	-	-
Resistance	x	x	x	-	-	-	-	-	-	-	-	-	-	-	-	-
Pt100 / Pt1000	x	x	x	-	-	-	-	x	-	-	-	-	-	-	-	-
Cryo Sensor	-	-	-	-	-	-	-	-	x	-	-	-	-	-	-	-
Thermocouple	x	x	x	-	-	x	x	-	-	-	-	-	-	-	-	-
Strain Gauge Full Bridge	x	x	x	-	-	-	-	-	-	x	x	x	-	-	-	-
Strain Gauge Half Bridge	-	-	-	-	-	-	-	-	-	x	x	x	-	-	-	-
Strain Gauge Quarter Br.	-	-	-	-	-	-	-	-	-	x	x	x	-	-	-	-
Inductive Full Bridge	-	-	-	-	-	-	-	-	-	x	x	x	-	-	-	-
Inductive Half Bridge	-	-	-	-	-	-	-	-	-	x	x	x	-	-	-	-
LVDT	-	-	-	-	-	-	-	-	-	x	x	x	-	-	-	-
Potentiom. Transducer	x	x	x	-	-	-	-	-	-	-	-	x	-	-	-	-
Piezoresist. Transducer	-	-	-	-	-	-	-	-	-	-	-	x	-	-	-	-
Status	x	x	x	x	x	-	-	x	x	x	x	x	x	x	x	-
Frequency	-	-	-	-	-	-	-	-	-	-	-	x	-	x	x	-
Counter	-	-	-	-	-	-	-	-	-	-	-	x	-	x	x	-

Table 2.1. - Characteristics of the e.bloxx modules

2.3. Module Parts

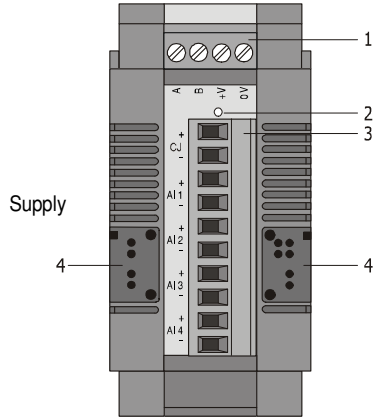

- 1 ... Pluggable Screw-Type Terminal Strip for Connection of RS-485 Bus and Power
- 2 ... Power/Error-LED (red/green)
- 3 ... Pluggable Screw-Type Terminal Strip for Sensor Connection
- 4 ... Rapid Bus Link Plugs

Picture 2.2. - Parts of the e-bloxx A4-1TC

Terminal Strip for RS 485 and Power Supply

Terminal	Description
A	RS 485 Bus Interface A
B	RS 485 Bus Interface B
+V	Power Supply +
0V	Power Supply -

Table 2.2. - Description of Terminal Strip for RS 485 Bus and Power Supply

Terminal Strip for Sensor Connection

Terminal	Description
CJ +	Cold Junction, +
-	Cold Junction
AI 1 +	Analog Input 1, +
-	Analog Input 1, -
AI 2 +	Analog Input 2, +
-	Analog Input 2, -
AI 3 +	Analog Input 3, +
-	Analog Input 3 -
AI 4 +	Analog Input 4 +
-	Analog Input 4-

Table 2.3. - Description of Terminal Strip for Sensor Connection

2.4. Functional Overview

This manual describes the e.bloxx modules A4-1TC and A4-4TC. These modules are all 8-channel modules (real plus virtual). They differ only in the number of inputs. The e.bloxx A4-1TC has four analog inputs, the e.bloxx A4-4TC has 16 analog inputs.

Each e.bloxx module has 8 channels that can be defined. There are different types of channels. Up to 4 analog input channels define the type of measurement and different measurement settings. The other channels can be used to do arithmetical calculations or process the measured value (scaling, min/max, alarm), to preset a certain value that can be changed later via interface and for threshold monitoring. The channels are defined in the configuration table of the Configuration Software ICP 100.

The values of each channel can be read out via the RS 485 bus. It is possible to set a filter frequency of up to 1 kHz for the analog input. It determines how fast the measured value will be updated. The resulting update time depends on the number of measurements.

2.5. Front-LED

The LED at the front of the e.bloxx modules provides the following information:

LED green	Module works well, no signal overflow, no communication error...
LED red	general error like signal overflow, broken sense leads
LED red + short off period	general error like signal overflow, broken sense leads + communication timeout
LED green + short red flash	Signal ok + communication timeout
LED red fast flashing	global error, no suitable firmware

Notice: The LED will get red when the signal leaves the selected range and the error checking is activated (see ICP 100 column Range/Error).

2.6. DC-Isolation

The power supply, bus interface and analog inputs are DC-isolated from each other.

2.7. Functional Diagram

The following picture can describe the e.bloxx A4-1TC.

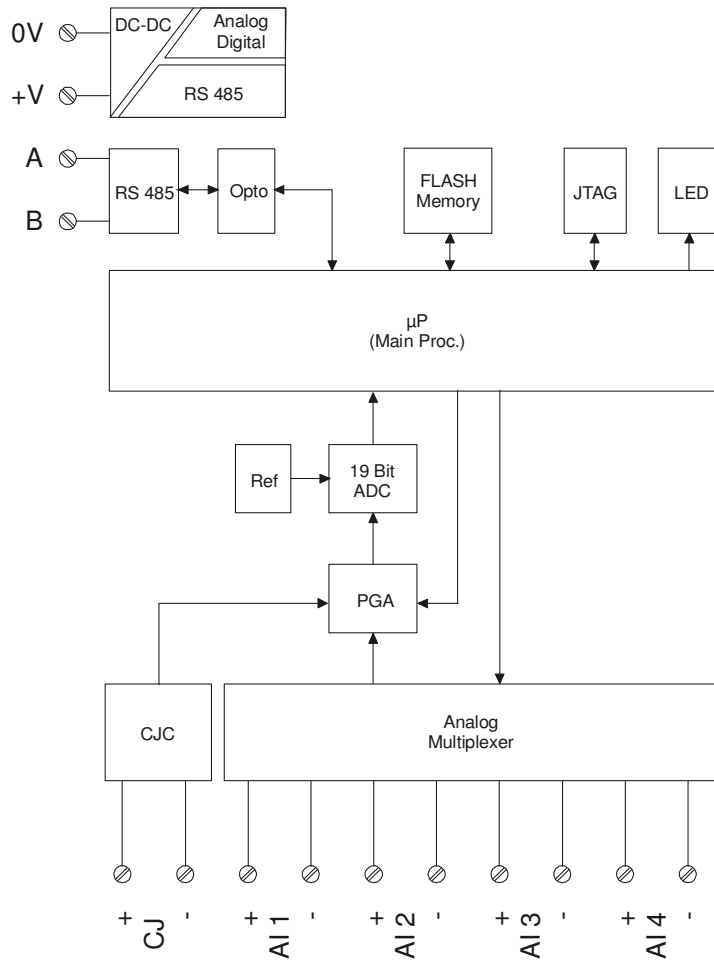

Picture 2.3. - Functional Diagram of the e.bloxx A4-1TC

3. MOUNTING e.bloxx AND CONNECTING WIRES

3.1. Environmental Conditions

The e.bloxx modules are protected against water and dirt according IP 20. If required by the conditions of the operating site the modules have to be installed accordingly, e.g. in a water-resistant or water-proof case, compliant with the regulations of electrical engineering.

For the allowed ambient temperatures for the e.bloxx A4-1TC and e.bloxx A4-4TC see the technical specifications at the end of this manual.

3.2. Connection Technique

The wires are connected to the modules via screw-type terminals. The captive terminal screws are part of the terminal strips. All terminal strips are of plug-in type and can be detached from the modules.

Not more than 2 leads should be connected with one clamp. In this case both leads should have the same conductor cross-section. For the precise clamping of stranded wire we recommend the use of wire-end ferrules.

Notice: Connecting wires respectively the plugging-in and -out of the terminal strip is only allowed with modules in power-off status.

In order to prevent interference with sensors, signals and modules, shielded cables have to be used for the power supply, bus connection and signal lines.

We strongly recommend using a single screened cable each input signal. To use more signals in one cable could generate interacting influences.

Notice: For optimal performance the e.bloxx modules must be grounded properly. This is achieved by utilizing the Ground/Earth screw on the back of each e.bloxx module. The screen of the sensor cable has to be grounded at the same potential.

3.3. Power Supply

Non-regulated DC voltage between +10 and +30 VDC is sufficient for the power supply of the modules. The input is protected against excess voltage and polarity connecting error. The power consumption remains approximately constant over the total voltage range, due to the integrated switching regulator.

Due to their low current consumption the modules can also be remotely supplied via longer lines. Several modules can be supplied in parallel within the permissible voltage range and drop in the lines. If required, the supply lines together with the bus line may be incorporated in one cable.

In order not to overload the module power supply needlessly and to avoid unnecessary line troubles, a separate power supply is recommended for sensors with a large current drain.

The distribution voltage for the e.bloxx modules has to be protected by a fuse with maximum 1 A (inert). The modules have an internal fuse (reversible) for protection against excess voltage, excess current and wrong polarity.

Notice: It depends on the power supply unit and its noise and internal grounding issues whether it is helpful to connect earth of the power supply unit with ground/earth of the e.bloxx module.

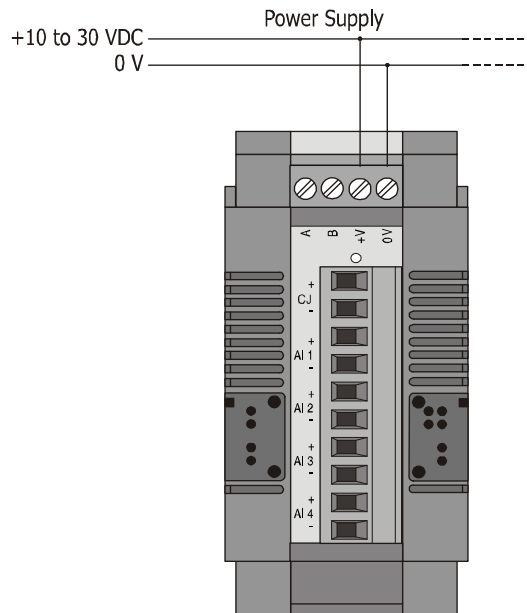

Picture 3.1. - Power Supply of the e.bloxx Modules

3.4. Bus Connection

Only the connection of the e.bloxx modules to the bus is described in here. A detailed description of the bus and the communication of the modules can be found in the Communication Guide of the e.bloxx/e.gate modules.

The e.bloxx Modules have an RS 485 bus interface for connection to the serial fieldbus. The bus has to be terminated on both sides with a characteristic impedance. The maximum line length depends on the transmission speed (refer to the Communication Guide for details) and can never be higher than 1.2 km per bus segment or 4.8 km via a physical bus string by using 3 repeaters. A maximum of 32 devices are possible with each bus segment and up to 127 devices via a physical bus string.

Wiring

In general, the e.bloxx is connected to the bus by connecting both signal leads A and B of the incoming bus cable and A' and B' of the outgoing bus cable together to one terminal on the module (Picture 3.2). Alternatively, the bus can also be connected by a "stub cable" (Picture 3.3). This guarantees that the bus connection to other modules remains in place, even if one module has to be exchanged, due to the removable terminal strip.

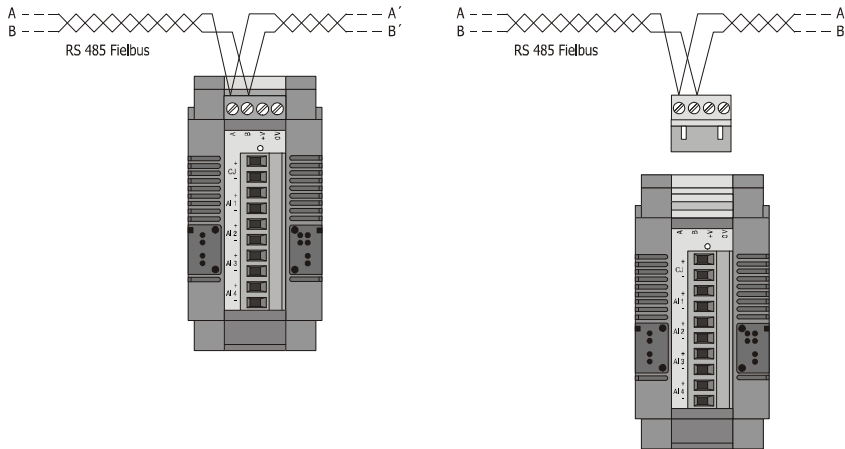

Picture 3.2. - Bus Connection of an e.bloxx A4-1TC to the RS 485 Fieldbus with Derivation

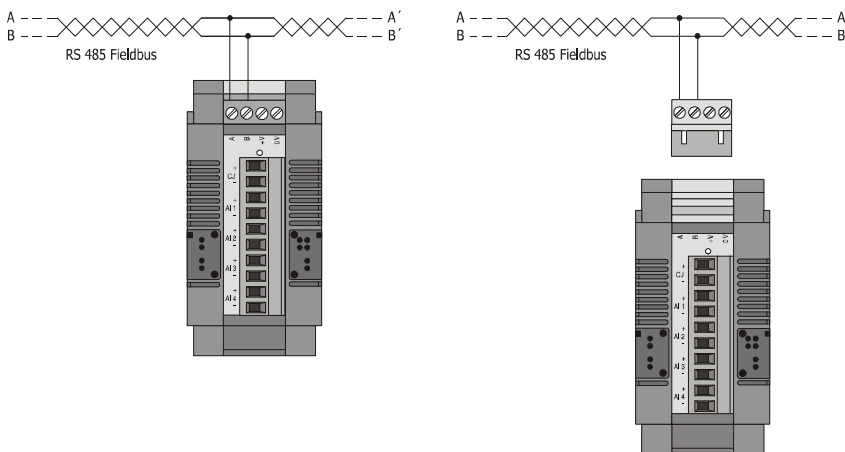

Picture 3.3. - Bus Connection of an e.bloxx A4-1TC to the RS 485 Fieldbus via Stub Cable

The stub-cable should be as short as possible, not longer than 30 cm.

Notice: The terminal designations A and B of all modules of the e.bloxx series are exchanged compared with the PROFIBUS-definitions. Consequently, in multi-vendor systems the bus lines A and B have to be exchanged when connecting them to the e.bloxx.

Bus Structure

The bus structure is a line structure where each bus segment will be terminated with characteristic impedance on both ends. Branches can be set up by means of a bi-directional signal amplifier, so-called repeaters. Other types of branches are not permitted (no tree topology). The max. stub-length to a user must not exceed 30 cm.

The following figures show a few examples of possible bus topology structures. The meanings of the symbols are as follows:

- ... Bus User
- ... Repeater
- ... Bus Termination

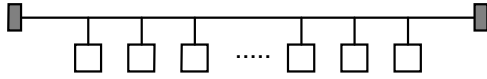

Picture 3.4. - Simple Line Structure

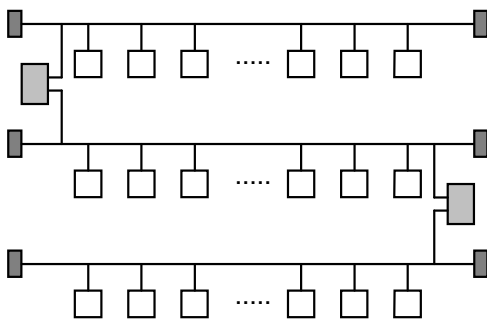

Picture 3.5. – Extended Line Structure

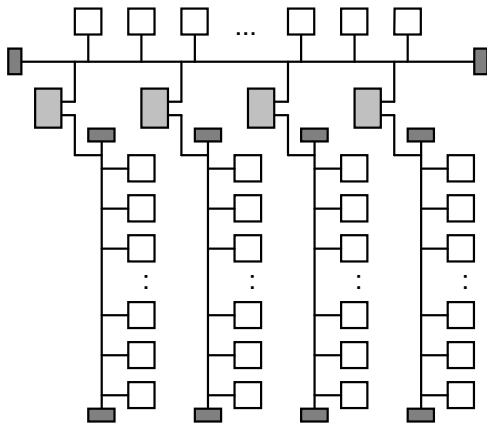

Picture 3.6. - Line Structure with Branches

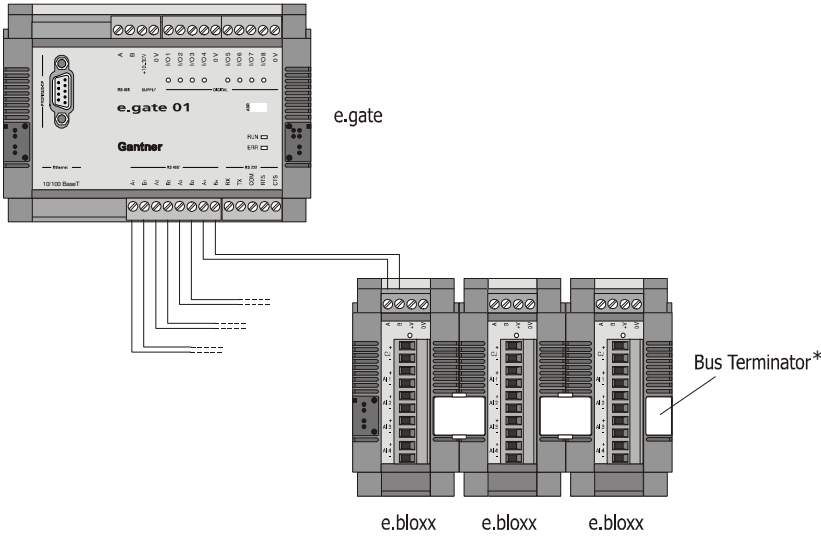

Picture 3.7. - e.bloxx A4-1TC and A4-4TC connected to e.gate

* ... If the e.bloxx A4-1TC and A4-4TC are used together with an e.gate, which is used to collect the data of all connected e.bloxx modules and processes them for fast transmission via the further network, a bus termination must be connected to the last e.bloxx in each bus line.

Bus Connection to PC

The bus interface of the e.bloxx is based on the RS-485 standard. Since most hosts are "only" equipped with RS 232 interfaces, an interface converter or a plug-in board with RS-485 drivers is required for conversion purposes.

Gantner Instruments Test & Measurement GMBH offers a compact interface converter, called ISK 200, with an integrated power supply and automatic baud rate detection. The power supply, bus connection and a separate 24 VDC-output are DC-isolated. Therefore, the interface converter ISK 200 is also applicable as a power supply for remote applications. Additionally, the interface converter ISK 200 features the option of connecting the required bus termination via a switch. The converter is designed to be used as a desk device.

Another module IRK 100 from Gantner Instruments Test & Measurement GMBH is available which may be used as an RS-485 repeater or RS 485/RS 232 converter. The baud rate can be adjusted at the IRK 100. Also, for this module the required bus termination may be connected with a switch. The Repeater/ Converter IRK 100 has a snap-on mounting mechanism for the installation on standard profile rails (DIN rail) 35 mm according to DIN EN 50022.

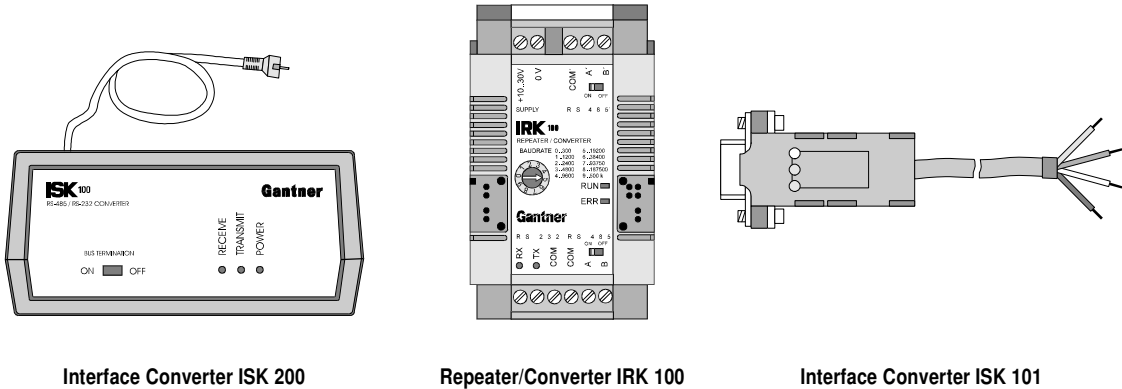

Picture 3.8. - Interface Converters ISK 200, IRK 100 and ISK 101

Bus Connection to Profibus-DP

For the installation of the bus cable and bus interface, 9-channel D-subminiature plugs and sockets are used. The pin assignment for the RS-485 connection according to PROFIBUS is given in Table 4.2.

Plug	Pin	RS 485 Notation	Signal	Identification
 DB 9	1	-	Shield	Shield, Protective Ground
	2	-	RP	Reserved for Power
	3	B / B'	RxD/TxD-P	Receive/Transmit-Data-P
	4	-	CNTR-P	Control-P
	5	C / C'	DGND	Data Ground
	6	-	VP	Voltage Plus
	7	-	RP	Reserved for Power
	8	A / A'	RxD/TxD-N	Receive/Transmit-Data-N
	9	-	CNTR-N	Control-N

Table 3.1. - Pin Assignment D-Subminiature Plug According to PROFIBUS

The signal leads A and B (and Shield) are mandatory for a (shielded) connection. Additional signal leads may be installed if required.

Notice: Due to the fact that the RS 485 interface is used for different protocols, in case of using Profibus-DP the leads A and B has to be crossed.

Bus Termination at the e.bloxx Modules

In order to avoid signal reflections on the bus, each bus segment has to be terminated at its physical beginning and at its end with the characteristic impedance. A terminating resistor is installed between the bus leads A and B for this purpose. In addition, the bus lead A is connected via a pull-up resistor to potential (VP) and the bus lead B is connected via a pull-down resistor to ground (DataGround). These resistors provide a defined quiescent potential in case there is no data transmission on the bus. This quiescent potential is level high.

The e.bloxx modules have these bus termination resistors built in. They can be connect to the bus by plugging the *Bus Termination Plug IBT 100*, which is available as accessory, into the rapid bus link plug on the front side of the module. Instead of the bus termination plug *IBT 100*, also separate jumpers may be used for the bus termination. In this case, it is mandatory that the jumper clips are installed as indicated below, and that the bus leads or the bus termination are not short-circuited by mistake.

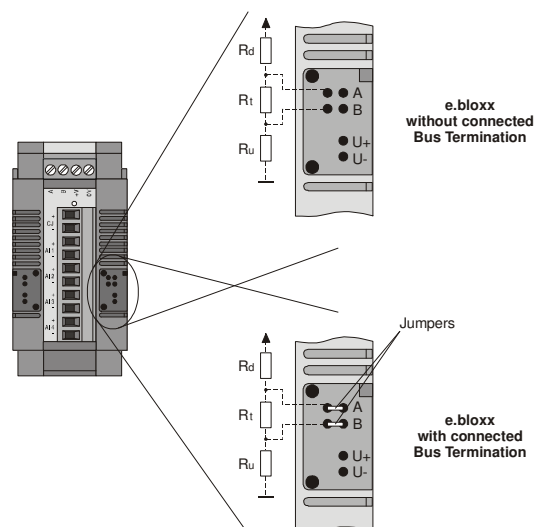

Picture 3.9. - Bus Termination at the e.bloxx Modules

3.5. Shielding

In case of increased interference, such as in industrial areas, we recommend shielding of bus and signal cables. In general, the shield should be connected to the protective grounding (not Data Ground!) at each bus connection. If necessary, the shield should also be applied along the course of the cable several times. For shorter distances, e.g. with stub cables, the interference response is often improved if the shielding is only applied to the stub cable exit.

Bus users such as controllers (PLCs), computers (PCs), repeaters and interface converters (ISK), etc., generally feature the possibility of applying the shield directly to the appliance or to separate shield rails. Shield rails offer the advantage of preventing possible interfering signals from reaching the appliance. The shields, which are connected to protective grounding, conduct interference signals off before reaching the module.

The e.bloxx do not have a direct shield connection at the module. Here the shield of the bus cable can be connected to earth e.g. by so-called shield clamps.

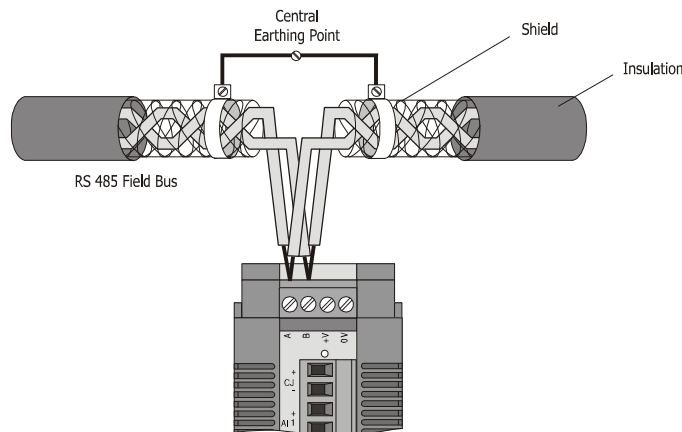

Picture 3.10. - Grounding of the Bus Line Shield at an e.bloxx

Notice: The shielding screen must not be connected to the ground (0V) of the power supply and it always should be connected to earth with a large surface and low-inductance.

3.6. Rapid Bus Link Plug

The e.bloxx have plugs on the left and right side, which allow connecting the bus and power supply from one module to the next with a Rapid Bus Link Plug (type designation: *ICM 100*). This kind of connecting bus and power supply is particularly advantageous if several modules are mounted on one common profile rail side by side. In this case, only the terminal of one module has to be connected. Furthermore, various modules of the e.bloxx series may be connected with the Rapid Bus Link Plug.

Notice: The current flowing through the Rapid Bus Link Plug Jack and the e.bloxx must not exceed 1 A. Thus, the power supply should preferably be connected to the middle of several modules and no more than 6 pieces of e.bloxx may be connected via the Rapid Bus Link Plug *ICM 100* in one line.

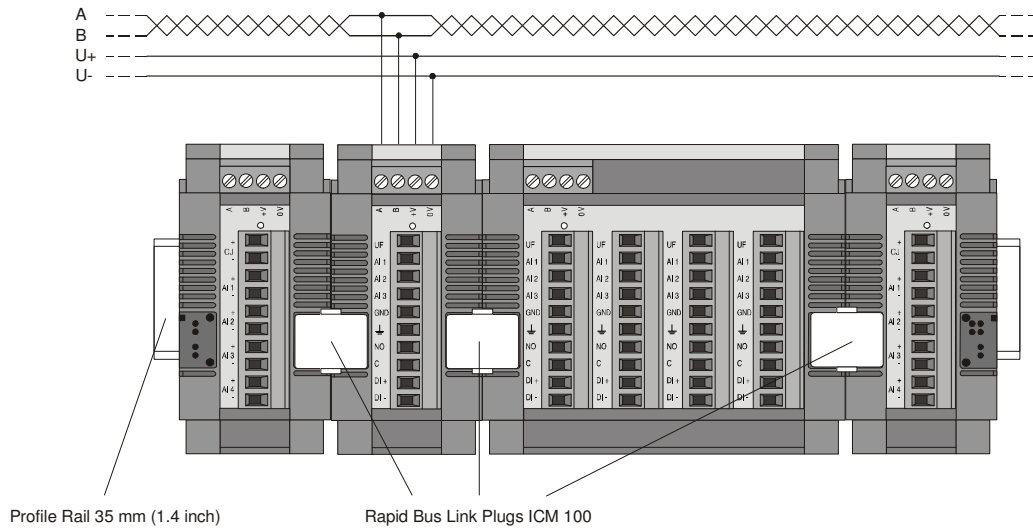

Picture 3.10. - Connection of four e.bloxx Modules with Rapid Bus Link Plugs ICM 100

4. MEASUREMENTS

4.1. General

The e.bloxx A4-1TC has 4 and the e.bloxx A4-4TC has 16 analog inputs. The configuration of the inputs is done with the Configuration Software ICP 100 as required by the application. For the e.bloxx A4-4TC the 4 physical inputs can be configured independently from each other.

Analog Input

The analog input collects and processes the signals of thermocouples or voltages. Currently data of a large number of standardized and proprietary thermocouples are stored in the e.bloxx. The user can input further sensor data:

- Measurement of Temperature with Thermocouples
- Measurement of Voltages in the range of ± 80 mV

Measuring with thermocouples 2 different types are available. The user can choose between internal and external cold junction compensation.

The analog input is protected against excess voltages.

Internal Reference Voltage

An internal reference voltage serves to balance the entire analog signal processing automatically.

4.2. Analog Input - Measurement of Temperature with Thermocouples

Connection Scheme

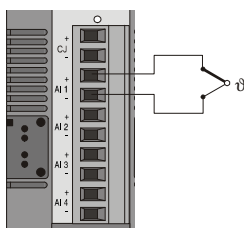

Circuit

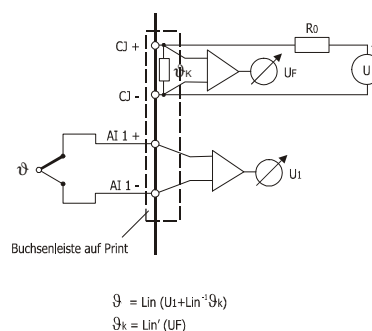

Picture 4.1. - Measurement of Temperature with Thermocouple - Internal Cold Junction Compensation

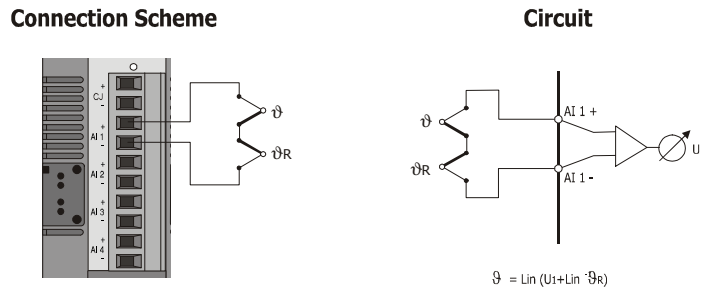

Picture 4.2. - Measurement of Temperature with Thermocouple - External Cold Junction Compensation

Thermocouples consist of two "thermoelectric wires" made of different materials (e.g. platinum and platinum rhodium) that are welded to each other at one end. If the contact position and the other ends of the thermoelectric wires have different temperatures, a "thermoelectric voltage" U_{th} appears at the contact position of both thermoelectric wires. This voltage is largely proportional to the temperature difference. It can be measured and can be used for temperature measurement purposes.

Since thermocouples can only measure a temperature difference (difference between temperature to be measured and temperature at the connecting terminals on the e.bloxx), a terminal temperature or a known temperature reference also have to be determined. In the first case this is called internal cold junction compensation (TC_{int}), in the second case external cold junction compensation (TC_{ext}).

When measuring the temperature with internal cold junction compensation an additional temperature sensor is used to measure a reference temperature ϑ_k . For the an e.bloxx A4-1TC or A4-4TC a Cold Junction Compensation clamp with a Pt1000 temperature sensor integrated – e.bloxx Terminal CJC – has to be used. The temperature of the test point is determined by the e.bloxx because of linearization trace to

$$\vartheta_x = \text{Lin}(U_x + \text{Lin}^{-1} \cdot \vartheta_k), \text{ where } \vartheta_k = \text{Lin}'(U_f).$$

If the temperature is measured by external cold junction compensation, a second thermocouple of the same type is required, which is connected in series with the first one. The polarity is selected in a way that the thermoelectric voltages subtract each other. The second thermocouple is set to a fixed reference temperature ϑ_r (mostly $\vartheta_r = 0 \text{ }^\circ\text{C}$). Then the e.bloxx calculates the temperature at the measuring position by means of the linearization curve as

$$\vartheta_x = \text{Lin}(U_x + \text{Lin}^{-1} \cdot \vartheta_r).$$

The e.bloxx will be informed about the reference temperature ϑ_r via the Configuration Software ICP 100 (Cold Junction Temperature).

4.3. Analog Input - Measurement of Voltage

Connection Scheme

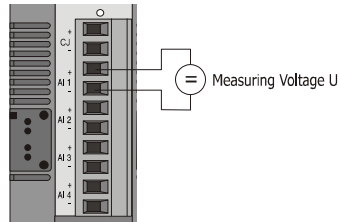

Circuit

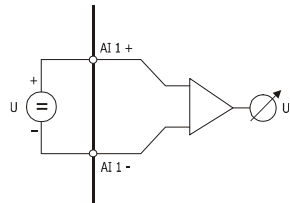

Picture 4.3. - Measurement of Voltage - Differential

The voltage to be measured is connected between "+" and "-" of an analog input (AI 1 .. 4). The measurement voltage must not exceed ± 80 mVDC.

5. CONFIGURATION

5.1. General Information about Configuration Software ICP 100

The e.bloxx modules can be configured with the Configuration Software ICP 100. This software includes all functions to set the module parameters like baud rate, measurement rate, etc. and to define the input and output functions like the type of measurements and the processing of the measured values.

The Configuration Software ICP 100 also includes a function to display measured values in real-time. There are also several software packages from other companies that are adapted to the specific measurement tasks.

In the Configuration Software ICP 100 the two register cards "Variable Settings" and "Module Settings" will be displayed if you are configuring an e.bloxx that is not online and also the two additional register cards "Info" and "Measure" when configuring an online e.bloxx.

- On the register card "Info" several module information will be displayed.
- On the register card "Measure" the channel values of the online e.bloxx will be displayed in real time.
- On the register card "Variable Settings" the different channels of the e.bloxx can be configured. This will be done in the Variable Settings Table being displayed on this register card.
- On the register card "Module Settings" different general settings like the baud rate, address, etc. can be defined for each e.bloxx.

This manual only gives a brief description on how to set up and configure an e.bloxx module. A detailed description of all the functions of the Configuration Software ICP 100 is included in the help function of the software.

5.2. Setting Address and Baud Rate of an e.bloxx

Before a control (PLC) or a computer (PC) can interchange data with an e.bloxx via the bus, address and baud rate of the e.bloxx have to be defined. The following points have to be taken into consideration in this connection:

- All devices have to be adjusted to the same baud rate.
- The same address must not appear twice in the bus topology.

The setting variants for the bus parameters for e.bloxx are:

Bus Parameter	ASCII Protocol	MODBUS Protocol	Profibus-DP	LOCAL-BUS Protocol
Address	1 127	1 127	1.....126	1 127
Baud Rate	19,200 bps	19,200 bps	19,200 bps	19,200 bps
	38,400 bps	38,400 bps	-	38,400 bps
	57,600 bps	57,600 bps	-	57,600 bps
	93,750 bps	93,750 bps	93,750 bps	93,750 bps
	115,200 bps	115,200 bps	-	115,200 bps
	-	-	187,500 bps	187,500 bps
	-	-	500,000 bps	500 kbps
	-	-	1.500 kbps	1.500 kbps

Table 5.1 - Setting variants for address and baud rate for the e.bloxx

If no other specifications are made on delivery, the e.bloxx have address 1 and baud rate 1.5 Mbps as default. The adjustment can be changed via the bus by means of the *Configuration Software ICP 100*.

Adjustment via bus by means of the Configuration Software ICP 100:

The address and baud rate of an e.bloxx can be set in the Configuration Software ICP 100. On the dialog box "Module Information" the address and baud rate of the actual e.bloxx is displayed. After changing these settings, the new settings have to be loaded into the e.bloxx in order to take effect. To do this the menu item **Send to Module** or **Send to Module as...** in the menu **File** or the corresponding button  in the icon bar has to be selected.

Notice: The address 0 is provided for the PC in case of a transmission via PROFIBUS-DP. This address can therefore not be assigned to the e.bloxx. Also the address 127 is reserved for broadcast transmission in the PROFIBUS-DP protocol and may only be assigned for these cases.

5.3. e.bloxx Settings

On the register card "Module Settings" the following settings of an e.bloxx can be defined.

- Location: Description of each e.bloxx.
- User Name: Possibility to enter the name of the person that has configured the module.
- Config. Date: Displays the date of configuration.
- Address: Address of the online e.bloxx. Will only be displayed if e.bloxx is online.
- Protocol: Bus protocol being used for communication between PC and e.bloxx. Will only be displayed if the e.bloxx is online. In the configuration software ICP 100 only the LocalBus protocol is displayed. Nevertheless all the protocols mentioned in chapter 2.2 are available and the e.bloxx uses the required protocol automatically.
- Character Format: Determines the number of data, parity and stop bits for transmission between PC and e.bloxx. Will only be displayed if e.bloxx is online. With the e.bloxx the character format is fixed to 8E1.
- Answer Delay: Determines how long an e.bloxx will wait before it sends an answer to a host request.
- Timeout: A timeout means that there is no communication with the module during the time period that is set here. All host-controlled functions (output via the Digital and Analog Output Variables and the Setpoint Variable) can be defined to pass into a safe, definable status. As soon as the communication recommences, the values are assumed again, depending on the configuration.
- Special Data: If a special program (firmware) is loaded in the e.bloxx it may need some special data that can be input here.

After changing some of these settings, the new settings have to be loaded into the corresponding e.bloxx, so they can take effect. Therefore select the menu item **Send to Module** or **Send to Module as...** in the menu **File** or the corresponding button  in the icon bar.

5.4. Definition of Channels

Up to 8 channels (real + virtual) can be defined for an e.bloxx. They define how the signals at the inputs and output of the e.bloxx will be processed. The value of every channel can be read out via the fieldbus. The channels are defined in the Variable Settings Table in the Configuration Software ICP 100.

The Variable Settings Table is displayed on the corresponding register card in the Configuration Software ICP 100.

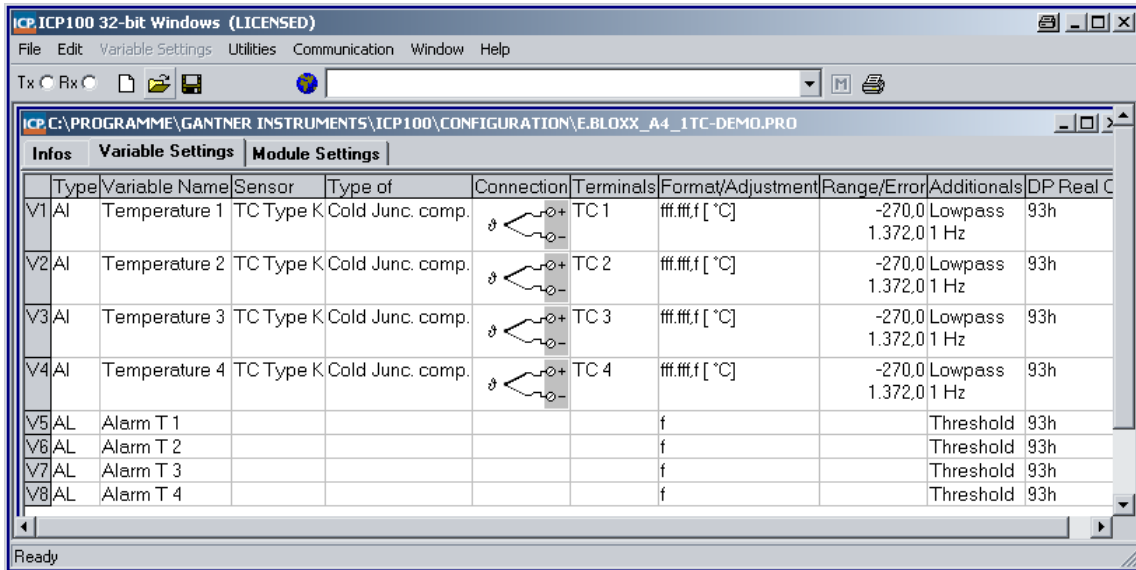

Picture 5.1. - Example for Variable Settings Table

Here all 8 possible channels will be listed. To define a new channel just click on a free line in the table or to change the type of channel click on the first column *Type* in the corresponding line. In both cases a dialog box will be opened where the type of the new channel has to be selected. There are 4 different types of channels:

- Analog Input Channel: Used to measure analog sensor signals. In the column *Sensor* the type of connected sensor is selected (thermocouple type, voltage) and in the next column the corresponding *Type of Measurement* is set (refer to chapter 4).
- Arithmetic Channel: With this channel it is possible to perform calculations with the actual values of other channels and with constant values. The results of the calculations are assigned to the arithmetic channel and so arithmetic channels can also be used by other arithmetic channels for calculations.
- Alarm Channel: An Alarm Channel can be used to monitor another channel and to generate an alarm message if one of up to 4 definable thresholds are exceeded. The alarm messages can be read via bus.
- Setpoint Channel: The value of this channel can be set via bus. This way it is possible to set a value via bus which can be used by an arithmetic channel for further processing, e.g. to set a factor for measurement by the user.

The settings for all defined channels will be displayed in the corresponding column of the channels. To change these settings click on the corresponding field in the Variable Settings Table.

Four analog inputs can be defined.

6. SPECIFICATIONS

All following data are valid after a warm-up time of the e.bloxx modules of approx. 45 minutes.

6.1. Analog Inputs

Accuracy	0.01 % typical 0.02 % in controlled magnetically environment according EN61326: 1997, appendix B 0.05 % in industrial area according to EN61326: 1997, appendix A		
Reliability	0.003 % typical (within 24 h)		
Type of Measurement	Range	Accuracy	Resolution
Voltages	±80 mV	±30 µV	4 µV
Thermocouples	Type B Type E, J, K, L, T, U Type N Type R, S	better than ± 5° better than ± 1° better than ± 2° better than ± 3°	
Common mode voltage	100 V permanent		
Linearity deviation	0.01 % of final value		
Temperature influence			
on zero	1 µV / 10 °K		
on sensitivity	0.01 % / 10 °K		
Long-time drift	1 µV / 24 h		

6.2. Analog/Digital Conversion

Resolution	19 bit
Sample rate	100 samples/sec for 4 active channels 400 samples/sec for one active channel
Conversion method	Sigma delta
Filter	Variable digital low pass filter 1 st order Averaging

6.3. Communication Interface

Standard	RS 485, 2-wire
Data format	8E1
Protocols	ASCII, Modbus-RTU, Profibus-DP, Local-Bus
Baud rates	
ASCII and Modbus-RTU	19.2, 38.4, 57.6, 93.75, 115.2 kbit/s
Profibus-DP	19.2, 93.75, 187.5, 500, 1500 kbit/s
Local-Bus	19.2, 38.4, 57.6, 93.75, 115.2, 187.5, 500, 1500 kbit/s
Connectable devices	up to 32 without repeater up to 127 with repeater
Galvanic isolation	500 V

6.4. Power Supply

Power supply	10 V to 30 VDC overvoltage and overload protection
Power consumption	
e.bloxx A4-1TC	approx. 1.5 W
e.bloxx A4-4TC	approx. 6 W
Influence of voltage	0.001 % / V

6.5. Mechanical

Case	Aluminium and ABS
Dimensions (W x H x D) and weight	e.bloxx A4-1TC: 45 x 90 x 83 mm (1.8 x 3.5 x 3.3 inch), 160 g e.bloxx A4-4TC: 104 x 90 x 83 mm (4.1 x 3.5 x 3.3 inch), 500 g
Protective system	IP 20
Mounting	DIN EN-Rail

6.6. Connection

Plug-in screw terminals	Wire cross-section up to 1.5 mm ²
Rapid bus connector	4-pin plug in ABS-housing

6.7. Environmental Conditions

Operating temperature	-20 °C to +60 °C (-4 °F to +140 °F)
Storage temperature	-30 °C to +85 °C (-22 °F to +185 °F)
Relative humidity	0% to 95% at +50 °C (+122 °F), non-condensing

7. DECLARATION OF CONFORMITY



Konformitätserklärung – Declaration of Conformity – Déclaration de Conformité

The undersigned, representing:

Gantner Instruments Test & Measurement GmbH
Montafonerstr. 8 – A-6780 Schruns /Austria
tel: +43/5556-73748-410 – www.gantner-instruments.com

herewith declares, that the product:

e.bloxx A4-1 TC

Certificate Ref No: 040603WG-03

is in conformity with the following EC directive(s), including all applicable amendments:

Directives	Short Title
X 89 / 336 / EEC	EMC Directive
99 / 5 / EEC	R&TTE Directive
73 / 23 / EEC	Low Voltage Directive
98 / 37 / EEC	Machinery Directive
99 / 519 / EEC	Limitation of human exposure to electromagnetic Fields

Only "X"-marked directives are relevant for the product and for this declaration of conformity !

and that the standards and/or technical specifications referenced below have been applied:

Standards	Short Title	
EMC	EN 61000-6-1 : 2001 X	Generic immunity standard for residential, commercial and light-industrial environments
	EN 61000-6-2 : 1999 X	Generic immunity standard for industrial environments
	EN 61000-6-3 : 2001	Generic emission standard for residential, commercial and light-industrial environments
	EN 61000-6-4 : 2001 X	Generic emission standard for industrial environments
	EN 61326: 1997+A1+A2 X	Electrical equipment for measurement, control and laboratory use – EMC requirements
R&TTE	EN 300220-1/3 : 2000	Electromagnetic compatibility for Short Range Devices (SRDs) from 25 to 1000 MHz
	EN 300330-1/2 : 2001	Electromagnetic compatibility for Short Range Devices (SRDs) from 9 kHz to 25 MHz
	EN 301489-1/3 : 2001	Electromagnetic compatibility for Short Range Devices (SRDs) from 9 kHz to 40 GHz
Safety	EN 61010 : 2001	Safety requirements for electrical equipment for measurement, control and laboratory use
	EN 60950 : 2000	Safety requirements for information technology equipment
	EN 60335 : 2002	Safety of household and similar electrical appliances
	EN 60601 : 1988	Safety requirements for medical electrical equipment
Machinery	EN 292-1/2: 1991	Safety of machinery – Basic concepts, general principles for design
	EN 954-1: 1996	Safety of machinery – Safety-related parts of control system
	EN 60204-1:1997	Safety of machinery – Electrical equipment
Human Expos.	EN 50364 : 2001	Limitation of human exposure to electromagnetic fields
	EN 50371 : 2002	Limitation of human exposure to electromagnetic fields (10MHz-300GHz) – Generic Standard

Remarks: Only "X"-marked standards are relevant for the product and for this declaration of conformity! Concerning safety aspects, the general and the product specific warning and safety instruction in the product accompanying documents must also be regarded!

This declaration is based upon the respective technical documentation held by the manufacturer.



Schruns, 03rd June 2004

Gantner Instruments

Test and Measurement GmbH
Montafonerstr. 8, A-6780 Schruns
T +43 5556 73748-410 F +43 5556 73748-419
www.gantner-instruments.com

Werner Ganahl, General Manager

Gantner Instruments Test & Measurement GmbH

Montafonerstr. 8 – A-6780 Schruns
Tel. + 43 5556 - 73748 - 410
Fax + 43 5556 - 73748 - 419
Firmenbuch FN 245174a UID-ATU57733723

Industriestr. 12 D-64297 Darmstadt
Tel. + 49 6151 - 95136 - 0
Fax + 49 6151 - 95136 - 26

HRB 9169 AG Darmstadt UID-DE814015743

Geschäftsführung: Werner Ganahl, Reinhard Kehrer
office@gantner-instruments.com
www.gantner-instruments.com

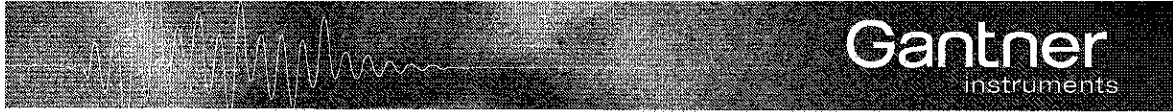

Konformitätserklärung – Declaration of Conformity – Déclaration de Conformité

The undersigned, representing:

herewith declares, that the product:

Gantner Instruments Test & Measurement GmbH
Montafonerstr. 8 – A-6780 Schruns /Austria
tel: +43/5556-73784-410 – www.gantner-instruments.com

e.bloxx A4-4 TC

Certificate Ref No: 040603WG-04

is in conformity with the following EC directive(s), including all applicable amendments:

Directives	Short Title
X 89 / 336 / EEC	EMC Directive
99 / 5 / EEC	R&TTE Directive
73 / 23 / EEC	Low Voltage Directive
98 / 37 / EEC	Machinery Directive
99 / 519 / EEC	Limitation of human exposure to electromagnetic Fields

Only "X"-marked directives are relevant for the product and for this declaration of conformity !

and that the standards and/or technical specifications referenced below have been applied:

Standards	Short Title	
EMC	EN 61000-6-1 : 2001 X	Generic immunity standard for residential, commercial and light-industrial environments
	EN 61000-6-2 : 1999 X	Generic immunity standard for industrial environments
	EN 61000-6-3 : 2001	Generic emission standard for residential, commercial and light-industrial environments
	EN 61000-6-4 : 2001 X	Generic emission standard for industrial environments
	EN 61326: 1997+A1+A2 X	Electrical equipment for measurement, control and laboratory use – EMC requirements
R&TTE	EN 300220-1/3 : 2000	Electromagnetic compatibility for Short Range Devices (SRDs) from 25 to 1000 MHz
	EN 300330-1/2 : 2001	Electromagnetic compatibility for Short Range Devices (SRDs) from 9 kHz to 25 MHz
	EN 301489-1/3 : 2001	Electromagnetic compatibility for Short Range Devices (SRDs) from 9 kHz to 40 GHz
Safety	EN 61010 : 2001	Safety requirements for electrical equipment for measurement, control and laboratory use
	EN 60950 : 2000	Safety requirements for information technology equipment
	EN 60335 : 2002	Safety of household and similar electrical appliances
	EN 60601 : 1988	Safety requirements for medical electrical equipment
Machinery	EN 292-1/2: 1991	Safety of machinery – Basic concepts, general principles for design
	EN 954-1: 1996	Safety of machinery – Safety-related parts of control system
	EN 60204-1:1997	Safety of machinery – Electrical equipment
Human Expos.	EN 50364 : 2001	Limitation of human exposure to electromagnetic fields
	EN 50371 : 2002	Limitation of human exposure to electromagnetic fields (10MHz-300GHz) – Generic Standard

Remarks: Only "X"-marked standards are relevant for the product and for this declaration of conformity! Concerning safety aspects, the general and the product specific warning and safety instruction in the product accompanying documents must also be regarded!

This declaration is based upon the respective technical documentation held by the manufacturer.



Schruns, 03rd June 2004

Gantner Instruments

Test and Measurement GmbH
Montafonerstr. 8, A-6780 Schruns
+43 (0)5556 73784-410, +43 (0)5556 73784-419
www.gantner-instruments.com

Werner Ganahl, General Manager

Gantner Instruments Test & Measurement GmbH

Montafonerstr. 8 A-6780 Schruns
Tel. + 43 5556 - 73784 - 410
Fax + 43 5556 - 73784 - 419

Industriest. 12 D-64287 Darmstadt
Tel. + 49 6151 - 95136 - 0
Fax + 49 6151 - 95136 - 24

Geschäftsführung: Werner Ganahl, Reinhard Kehrer
office@gantner-instruments.com

Firmenbuch FN 245174a UID ATU577337Z3

HRB 9169 AG Darmstadt UID DE814015743

www.gantner-instruments.com

e.bloxx A4-1TC, A4-4TC

Notice:

Information in this manual are valid from March 2006 until revocation.
Further changes and completion of the manual are reserved and possible without notice.

e.bloxx A4-1TC, A4-4TC

—— www.gantner-instruments.com ——

Gantner Instruments Test & Measurement GMBH
Montafonerstraße 8 • A-6780 Schruns/Austria
Tel.: +43 (0)5556-73784-410 • Fax: +43 (0)5556-73784-419
E-Mail: office@gantner-instruments.com

Gantner
instruments